

Shape Memory Alloys Application: Trailing Edge Shape Control

Benoit BERTON
Dassault Aviation
78 quai M. Dassault
92552 St Cloud Cedex
FRANCE

benoit.berton@dassault-aviation.com

ABSTRACT

Following several studies in the field of Active or Smart materials and Structure (SMS) (material characterization, simulation of performances), Dassault Aviation has proposed, in the frame of an European project, to evaluate the capabilities of Smart Materials and Structures applied to an adaptive divergent trailing edge of a High Altitude Unmanned Air Vehicle. A demonstrator of this adaptive trailing edge has been designed and manufactured. An original actuation concept has been developed based on a mixed system made of push-pull SMA (Shape Memory Alloy) wires connected to mechanical links that actuate the trailing edge. Functional tests were performed on the demonstrator in the Argenteuil Dassault Aviation laboratory, including characterization at low temperature. From this experimental campaign and from the subsequent analysis, the initial specifications have been fulfilled in term of force, deflection, actuation time, energy consumption and temperature range. This shows that the design is adequate and could be applied to an existing air vehicle. Nevertheless, some improvement would be useful on the SMA behaviour understanding and on their procurement.

1.0 INTRODUCTION

DASSAULT AVIATION has been involved in the field of Active or Smart materials and Structure (SMS) for more than 10 years. Then, studies have been carried out either on the technology evaluation (tests on piezoelectric materials or Shape Memory Alloys (SMA) or on design and computations of such structures applied to an aircraft. This work has allowed DASSAULT AVIATION to identify the potential applications of SMS on military aircraft, business jets and UAV. In particular, it appeared indeed that local shape modification of aerodynamic surfaces could lead to interesting performances.

2.0 VIEW AND NEEDS OF DASSAULT AVIATION ON MULTIFUNCTIONAL (OR SMART) STRUCTURES

2.1 Potential applications on aircraft

The envisaged applications of multifunctional structures on Dassault aircraft are listed below:

- Active Control and reduction of noise and vibrations
 - control of aero-acoustic excitations
 - active suspension of equipment
 - reduction of internal noise in business jets

Berton, B. (2006) Shape Memory Alloys Application: Trailing Edge Shape Control. In *Multifunctional Structures / Integration of Sensors and Antennas* (pp. 13-1 – 13-16). Meeting Proceedings RTO-MP-AVT-141, Paper 13. Neuilly-sur-Seine, France: RTO. Available from: <http://www.rto.nato.int/abstracts.asp>.

Shape Memory Alloys Application: Trailing Edge Shape Control

- Shape control of aerodynamic surfaces
- Active fluid dynamics
- Health monitoring of structures
- Integrated antennas and electromagnetic structures

However, amongst these applications, the level of interest in Dassault is very varied. Indeed, rather limited efforts have been put on Health monitoring or active vibration control. For these 2 applications, existing passive devices can exhibit good performances and are rather cost effective. For instance, an integrated health monitoring system can only be considered if it leads to reduction of cost of ownership in comparison to current NDI methods. Moreover, it must demonstrate its own maintainability for more than 30 years. Concerning active control of vibrations, most of the proposed systems are based on piezoceramic materials which show rather limited performances in comparison to classical visco-elastic patches and are far more complex and costly to use.

To the contrary, applications with the objective to increase the aerodynamic performances of aircraft surfaces seem rather promising. This goal can be first achieved by injecting or pumping air directly in the boundary layer (active aerodynamic). Dassault has participated to such Research program for several years. An other means is to modify the shape of external surfaces for improvement of flight control (in replacement of ailerons) or for reduction of drag. Internal studies have been carried out to quantify the expected benefits of such systems. Figure 1 shows the deformation obtained on a Falcon wing with Shape memory alloys actuators for roll control of the aircraft. Similar studies were performed on Rafale aircraft.

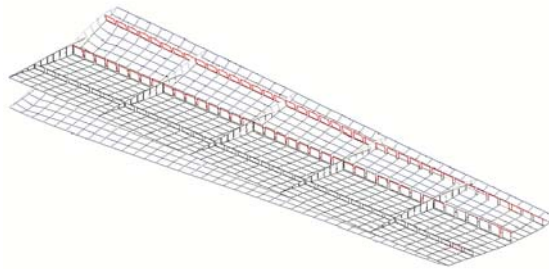

Figure 1: Deformation of Falcon wing with SMA actuators for roll control.

From these simulations studies, specifications of suitable active materials have been determined, especially in terms of deformation authorities, forces, frequency response... The figure 2 below illustrates the needs of performances in frequency and displacement for different types of aircraft applications.

Shape Memory Alloys Application: Trailing Edge Shape Control

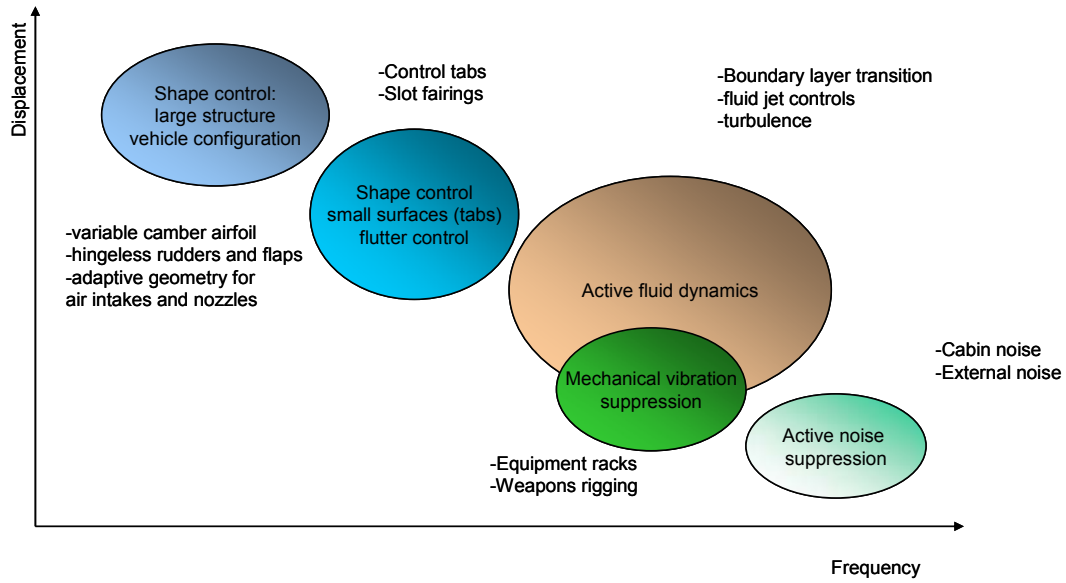

Figure 2: Smart actuators specification for different airframe application.

Starting from these general specifications, it is possible to compare them with the properties of current active materials as they are summarised in the table 1. In this table are only considered industrial materials. Other materials, such as single crystal piezoceramic are still laboratory materials for an airframer since not on the global aerospace market.

Table 1: General properties of different active materials for actuation

	PZT G-1195 (piezoceramic)	PVDF	PMN (electro- strictive)	Terfenol D (magneto- strictive)	Nitinol Shape memory alloy
Density	7.5	1.8		9.2	6.5
Young's modulus (GPa)	70	2-3	120	50	90 (a) 30 (m)
ultimate elongation (%)	0.1 - 0.2	20	0.1		4
Use temperature (°C)	120 - 160	60		200	variable
Max electric field (V/mm)	1000	40000		10V	
deformation authority (max field μ def)	250 (d_{31}) 600 (d_{33})	2000	1000	2000	20000
Bandwidth	high	high	high	medium (150- 3000 Hz)	low (few Hz)

From the benefits analysis of different applications and the capabilities of current active materials, it appears that the most realistic and beneficial application on a short term basis is the shape control of small aerodynamic surfaces. For such application, Shape memory alloy seems the most convenient actuation material. It was then decided to launch at Dassault a development programme on this application.

Shape Memory Alloys Application: Trailing Edge Shape Control

3.0 APPLICATION : SHAPE CONTROL OF AN UAV TRAILING EDGE

Dassault Aviation has been actively involved in the field of Unmanned Aircraft Vehicle (UAV) for a while. Main efforts are set on Combat UAV or UCAV. A first small test vehicle, called Petit Duc, has flown some years ago and Dassault is now leading an European cooperation to develop a large UCAV integrating stealthy design to fly in 2010 : Neuron.

Other studies are related with tactical UAV and also HALE (high Altitude Long Endurance) UAV. For the latter vehicle, aerodynamic optimisation of the wings is important in order to enhance the endurance. Especially, the capability to reduce the wave drag in transonic cruise at flight altitude without increasing the drag at lower Cl or lower Mach number is very interesting. This can be achieved by modifying the shape of the trailing edge from a divergent one at flight altitude to a straight one in the transition regimes.

To achieve this shape modification, it is interesting to consider a multifunctional structure using shape memory alloys as actuators. Such development has been launched at Dassault in the frame of an European EUCLID research program : CASS.

3.1 Operational and Functional Requirements

Operational Requirements :

For an HALE vehicle, the normal flight conditions are for a Mach number of 0,7 and a cruise altitude at 60000 ft. This leads to a flight temperature of the trailing edge around -55°C .

The active part shall be actuated once arriving at the flight altitude and is retracted when the descent is starting. Therefore, the system is operating two times per flight. Since the primary objective is for drag reduction, response time can be low. In the initial specifications, an aim of 10 seconds was indicated but even **one minute** could be acceptable.

As flight durations are typically 10 hours or more, the life duration of the device would be typically about 1000 to 2000 cycles. However, it is envisaged, if necessary, to replace it on ground every 1000 cycles.

The adaptive trailing edge shall also be compatible with the space available for an HALE aileron.. It shall also be compatible with the electrical power available on such a vehicle.

Functional Specifications :

At the beginning of the programme, an initial specification of the moving trailing edge has been set up as shown on figure 3 :

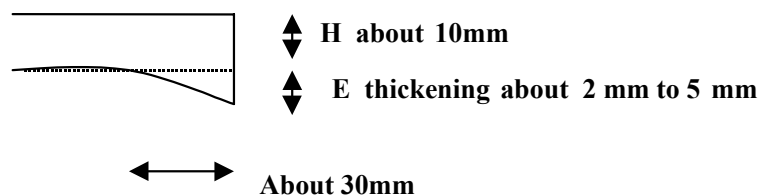

Figure 3: Initial geometrical specifications.

Starting from this initial specifications, further aerodynamic computations have been made in order to optimise the drag performances. Figure 4 shows geometries simulated with higher angle of deflections.

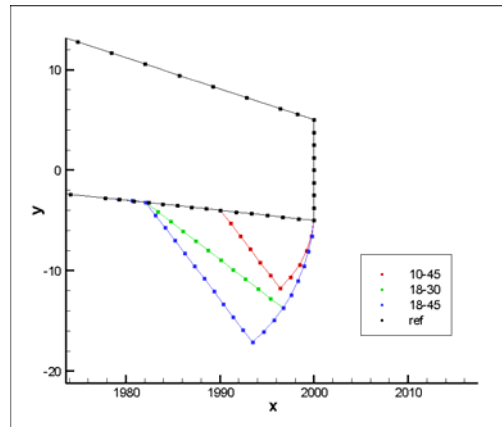

Figure 4: Trailing edge geometries for the aerodynamic computations.

These simulations have demonstrated that relevant parameters for this kind of device are :

- Efficient trailing edge base thickening of same order of magnitude that the basic trailing edge (0.5% of the chord).
- Angle of wedge higher than 30° (limit value of 90° corresponds to the little plate perpendicular to the flow called gurney flap). Optimum angle is around 45°.

Finally, the geometry with a moving part of **18 mm** long and an angle of deflection of **45 °** exhibited very high performances. This second specifications has been taken for the design of the final demonstrator.

Aerodynamic Benefits

The figure below, obtained from in-house Navier&Stokes aerodynamic computations shows a typical gain in drag around 5% at low Cl by using this adaptive divergent trailing edge.

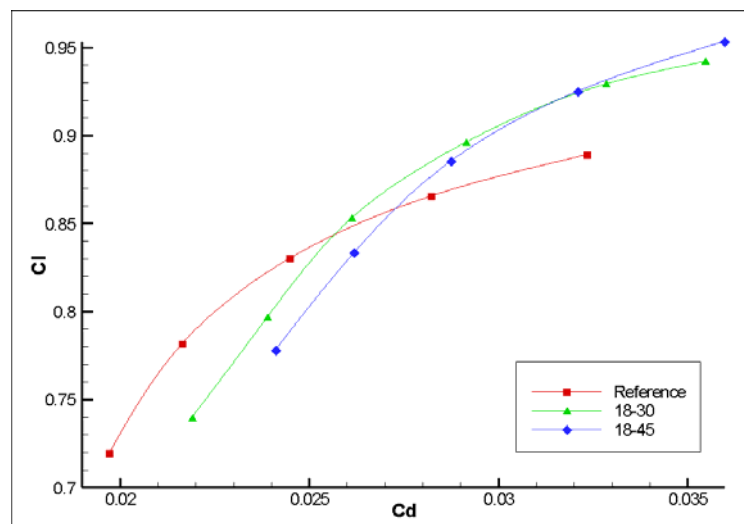

Figure 5: Lift coefficient vs drag coefficient for different geometries of trailing edge (ref fig 4).

From these computations, the aerodynamic loads applying on the trailing edge were also determined and are shown on figure 6 below :

Shape Memory Alloys Application: Trailing Edge Shape Control

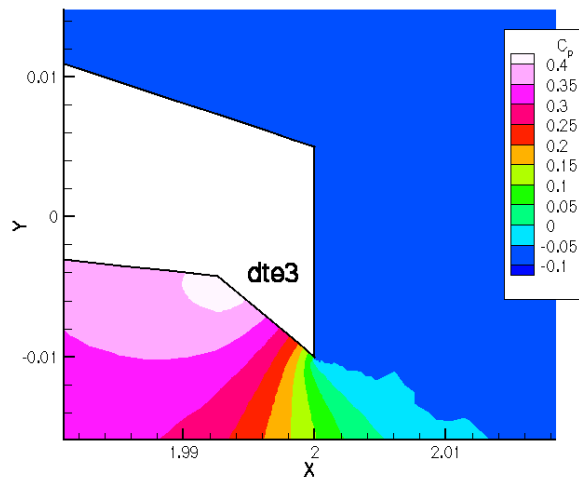

Figure 6: aerodynamic loads on the trailing edge.

At the flight altitude where the divergent trailing edge is unfolded, they stand around 1000 N/m^2 .

3.2 Design of the Smart Actuation System

3.2.1 Specifications Summary

As presented in the previous chapter, the final concept selected is based on the following specifications (see fig. 7) :

- length of the wedge : $L = 18$ to 20 mm
- open angle of the wedge : $\alpha = 30$ to 45°
- aerodynamic pressure $P : 1000 \text{ N/m}^2$

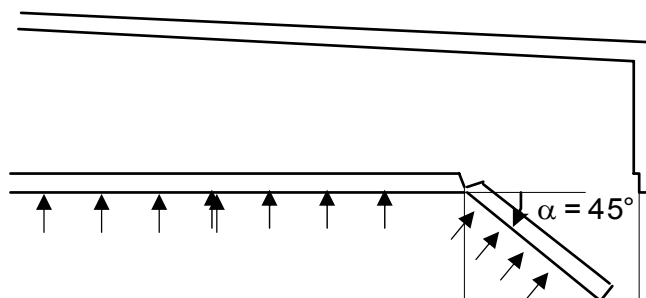

Figure 7: Adaptive trailing edge with specifications.

3.2.2 Definition of the Actuation System

The actuation system is a mixed system made of push-pull SMA wires connected to mechanical links that actuate the trailing edge. Figure 8 show a cross section of the mechanism.

Shape Memory Alloys Application: Trailing Edge Shape Control

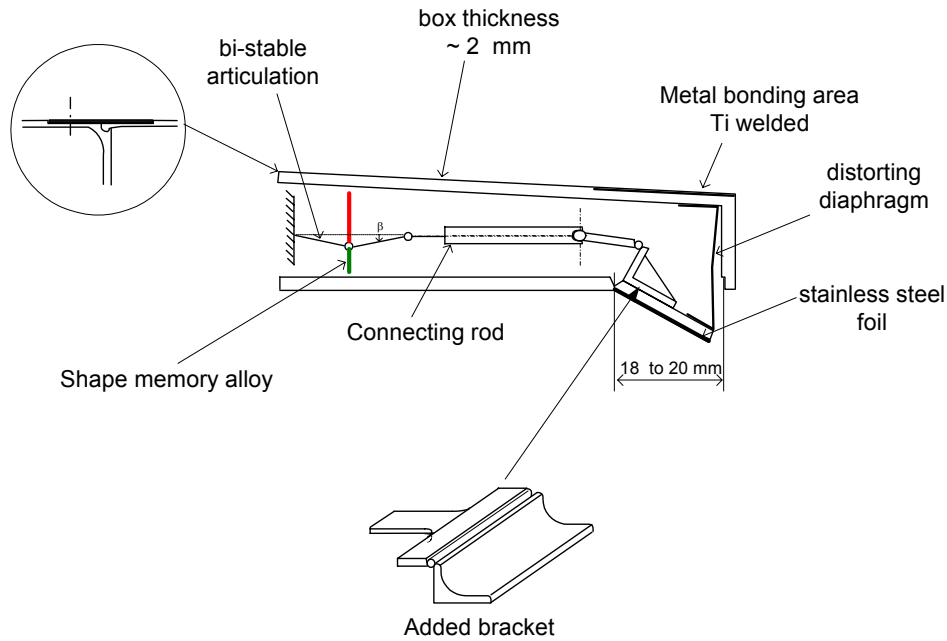

Figure 8: Cross section of the selected concept.

3.2.3 Running of the Actuation System

The actuation system is made of two opposing SMA (Shape Memory Alloy) wires. A green one for the opening of the wedge and an other red one for the closing. They are both fixed to the opposite side-wall (ribs) and to the articulation which transmit strength and movement to the other articulation through rods.

Shape Memory Alloys Application: Trailing Edge Shape Control

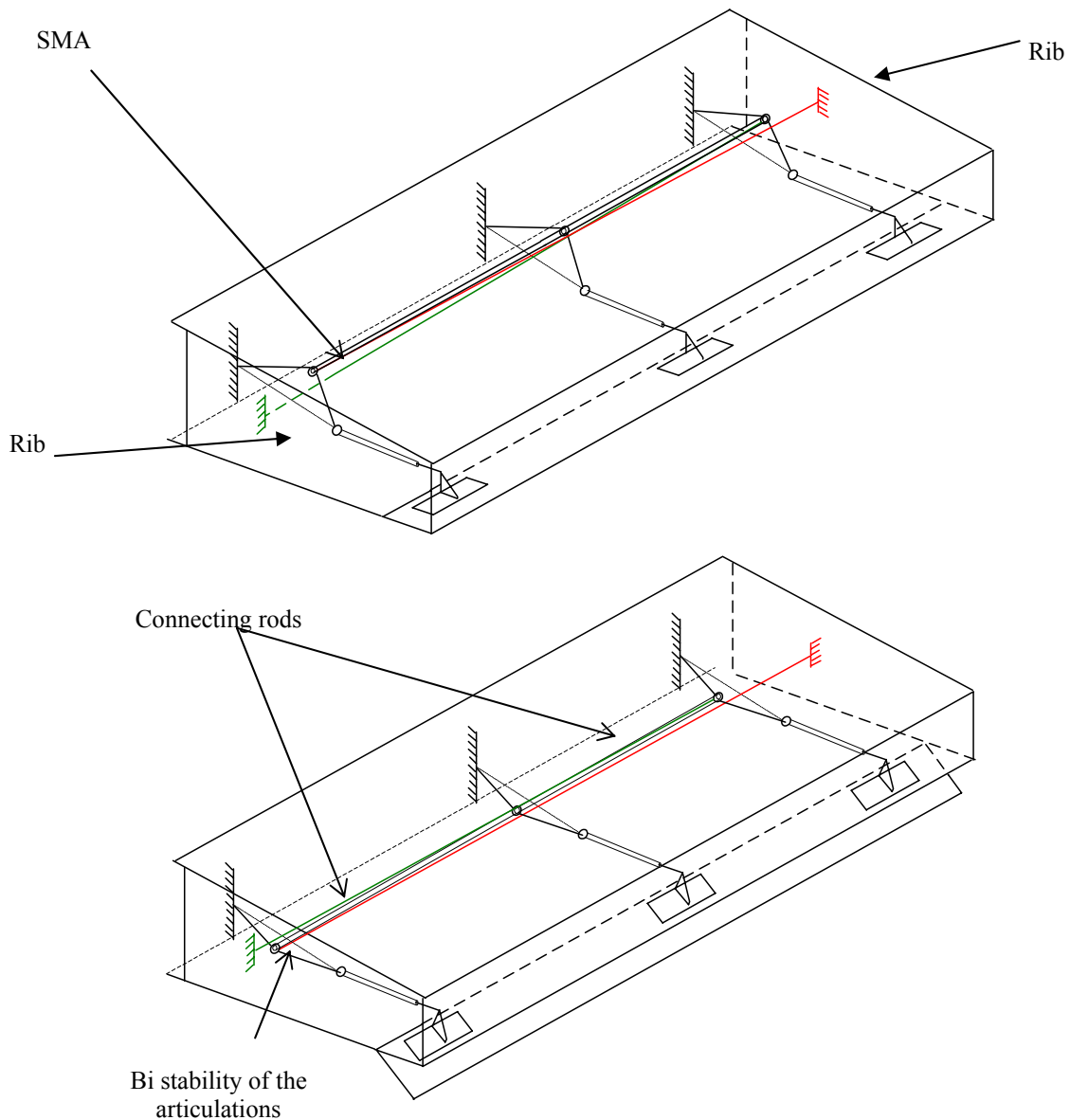

Figure 9: Principle of running order of the SMA actuation system.

3.2.4 Sizing of the Actuation Components

An Excel Macro sheet has been built in order to calculate the forces and the displacements in the links and in the SMA wires needed to operate the trailing edge. The Figure 10 shows a schematic of the forces applying on the system. Finally, the SMA diameter could be deduced from these calculations.

Shape Memory Alloys Application: Trailing Edge Shape Control

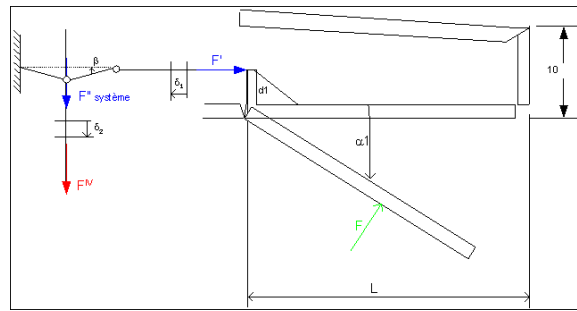

Figure 10: Forces acting on the actuation system.

- Minimum diameter of the SMA (Shape memory Alloy) wires : $\phi = 0,7$ mm
- length of each SMA : ~ 450 mm
- deformation of the SMA wires : 11 mm (12,5 authorised for 500 mm length)
- SMA Voltage need : $\sim 2-5$ volts

3.3 Design and Manufacturing of the Trailing Edge Demonstrator

It has been decided to build a demonstrator in order to validate this original actuation concept. The demonstrator to be manufactured is based on the generic geometry of a wing aileron. External dimensions are 300 mm along the chord and 500 mm along the span. This aileron is split in 2 parts as shown on figure 11 :

- a forward box with the main function is to withstand the structural loads (200 mm along the chord).
- a rearward box with the adaptive part and the actuation system (100 mm along the chord). However, for spacing reasons, the SMA wires are located in the forward box (modified vs fig 9).

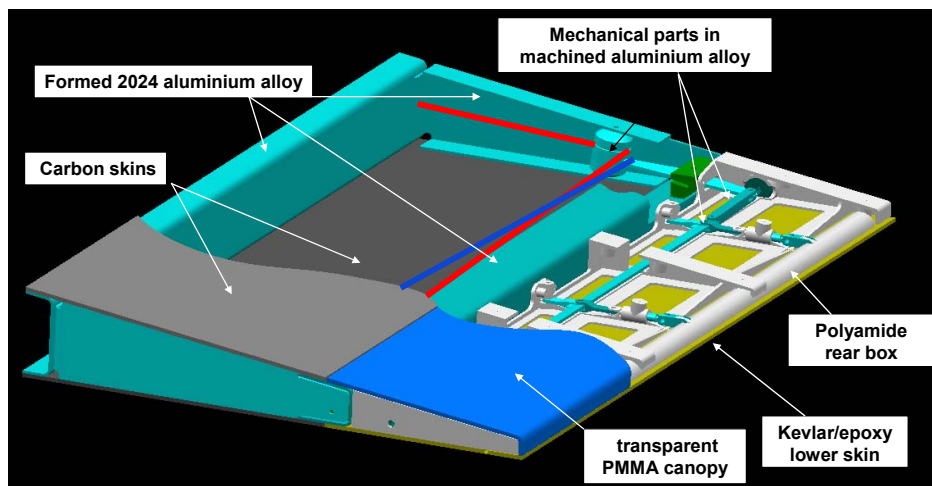

Figure 11: UAV Trailing edge demonstrator.

Shape Memory Alloys Application: Trailing Edge Shape Control

The materials used for the forward and rearward boxes are as follows :

- adaptive trailing edge : Aramid/epoxy composite.
- spar and ribs : Aluminium sheet (spar : 1,6mm thick, ribs: 2,5 mm)
- lower and upper skin : RTM process : carbon fiber / epoxy resin (2,5 mm)
- concerning the actuating system (bellcrank, small rods, toggle joint system....) are made in machined aluminium
- Aramid plate : 2,5mm thick
- Roller : polyamide (PA 6-6)

Concerning the SMA wires, the selected alloy is NiTi provided by French company Memometal. Several diameters were purchased (0,8-1-1,2 mm) but most of the tests have been performed with 1 mm diameter. The transformation hysteresis cycle of the selected alloy is between 40°C and 70°C.

For manufacturing, CATIA CAD files of all the individual parts have been made. The structural parts, skin, ribs, spars, hinge were manufactured at the Argenteuil and Biarritz (composite skins) Dassault plants. The polymeric parts and all the small mechanical parts were sub-contracted. The figures below show the different steps of integration of the demonstrator.

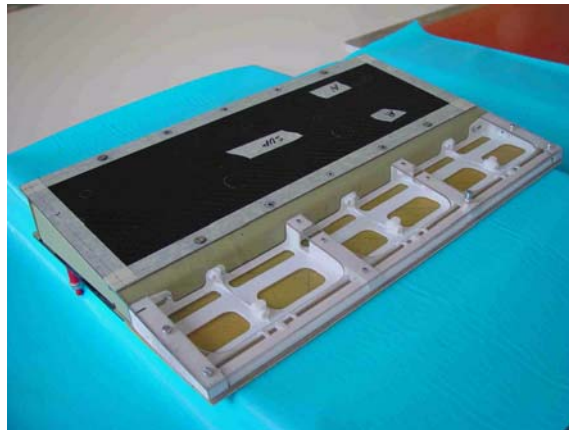

Figure 12: Integration of the forward box with the rearward box.



Figure 13: Detail of the actuation mechanism.

3.4 Experimental Evaluation of the Demonstrator

3.4.1 Characterization Program

Different steps were followed for this characterization program :

- Test on the elastic hinge technology
- Pre-straining of the SMA wires and identification of their thermal-electrical cycles
- Ageing of the SMA wires for hundreds of cycles on a specific test rig (to avoid initial length variation of the wires)
- Functional tests of the demonstrator at room temperature :
 - Static conditions
 - under cycles (1000-2000)
 - with mechanical loads
- Functional tests at low temperature (-55 °C)
 - in a specific climatic chamber
 - same conditions as at room temperature

3.4.2 Preparatory Tests

In advance to the characterization of the demonstrator, individual tests were carried out on the hinge material and on the SMA wires.

For the elastic hinge, functional tests were performed on 3 types of materials (metallic, polymer, kevlar)

- 10000 cycles at initial state at -55°C
- 5000 cycles after exposure to 75% relative humidity and -85°C

The best results were obtained with aramid composite (Kevlar) : the hinge didn't show any degradation and was selected on the demonstrator

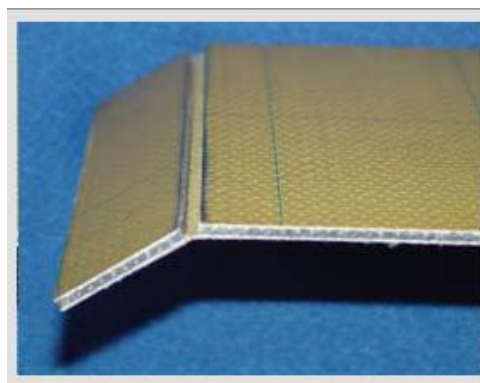

Figure 14: Elastic hinge.

For the SMA wires, two types of experiment were carried out. First, the SMA wires have been pre-strained in order to obtain the recovery force. This pre-straining has been done on a tensile machine by setting the deformation. A pre-strain of 4% has been applied on the 1 mm diameter wires (600 mm length).

Shape Memory Alloys Application: Trailing Edge Shape Control

Secondly, it was necessary to apply an ageing treatment on the SMA wires. Indeed, initial tests had shown that the wires tend to deform continuously during cycles representative of the flap functioning. Therefore, all the wires were cycled on the same test rig as for the demonstrator. Nearly 800 cycles are necessary to obtain a stabilisation of the wire elongation. The conditions were as follows :

- electrical current : 6A - 4 V
- elongation imposed = 14mm (~2,5%)
- strength : 75 N

3.4.3 Tests on the Demonstrator

A specific test rig, including a climatic chamber, has been developed in order to be able to apply a variable load on the trailing edge (figure 15). The same test rig has been used for the ageing of the SMA wires.

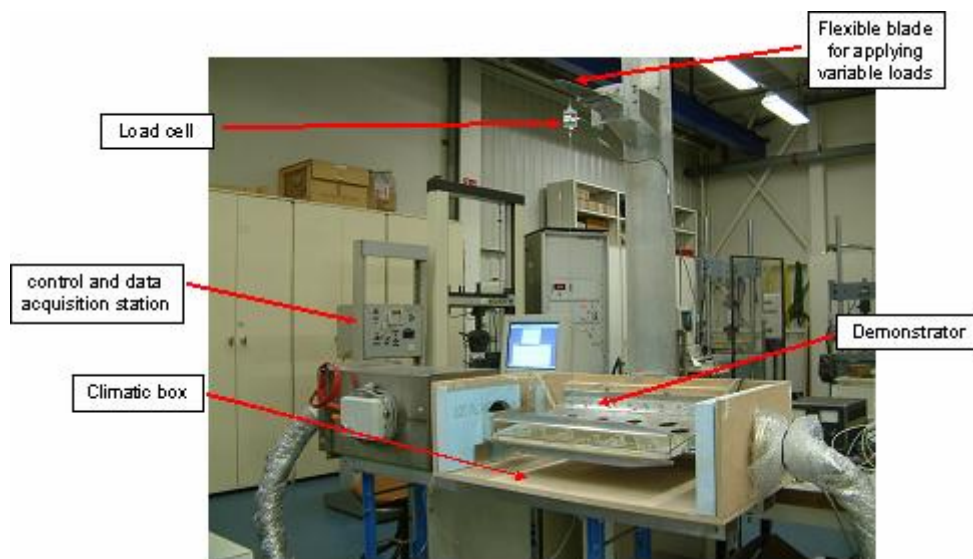

Figure 15: Characterization set-up in Dassault laboratory.

First, some primary functional tests have been performed without loading in order to verify if the needed deflection could be obtained, i.e. a complete opening of the flap (45° deflection angle). These first tests have confirmed a satisfactory running of the system and a confirmation of the correct sizing.

Then, one thousand cycles have been applied on the demonstrator with the representative aerodynamic load (75 N – extreme value) at Room temperature. The figure 16 below show the measurements performed by the sensors during several cycles. After 1000 cycles, no variation has been observed on the recording.

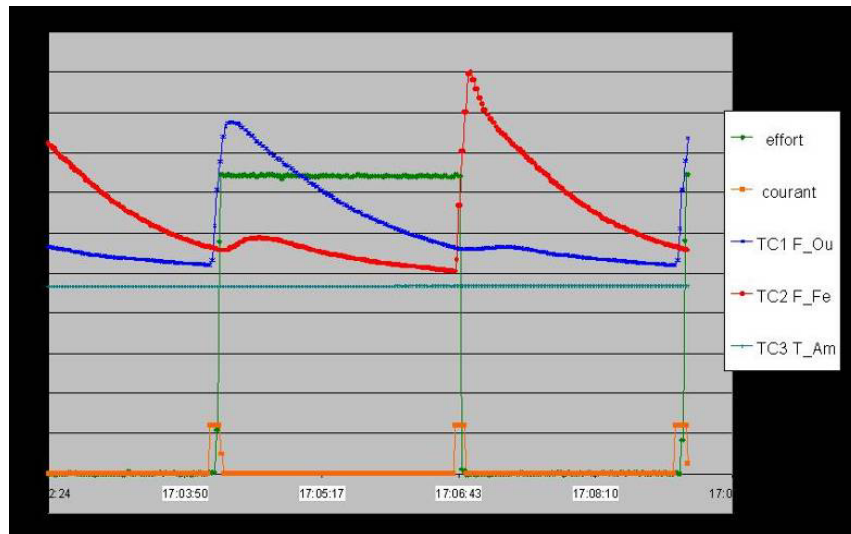

Figure 16: Experimental recordings.

The following recording were made during the cycles :

- mechanical load on the trailing edge (green curve)
- input electrical current (6 A)(orange curve)
- electrical switch corresponding to the opened TE
- electrical switch corresponding to the closed TE
- temperature of SMA wire n°1 (blue curve)
- temperature of SMA wire n°2 (red curve)
- temperature inside the demonstrator

Finally, the parameters of the system during these cycles were the following :

- time to open the flap = ~ 10 s
- time of cooling SMA : 2'30s
- total cycle time (TE opening + closing) = ~ 5'
- temperature of SMA wires : from 25°C to around 50°C

Similar tests were performed at low temperature. Unhappily, it was not possible to decrease to -55°C and the tests were carried at -35°C: After several cycles at this temperature, the parameters were as follows :

- time to open the flap = ~ 18 s
- time of cooling SMA from 32°C to -25°C : 1'40s

Considering the energy aspects, the needed electrical power at Room temperature was 24 Watt for the cycle duration chosen. This is compatible with available power in a HALE type UAV. At low temperature, nevertheless, it was needed to increase the power to reach the SMA transformation temperature. Naturally, the electrical power budget is dependant on the thermal insulation of the wires. However, it must be kept in mind that the energy yield (electrical/mechanical) of the system is very low: below 1%.

Finally, we can compare these results with the specifications given in chapter 3.1, as shown in table 2.

Shape Memory Alloys Application: Trailing Edge Shape Control

Table 2: Matrix of compliance

Requirements	Experimental verification
Geometrical deformation (deflection angle)	OK
Response time	OK
Aerodynamic loads	OK
Available space	OK (including battery)
Available power	OK (for a HALE type)
Cycle life	~OK (complementary tests would be useful)
temperature	Partially demonstrated (to – 35°C)

4 CONCLUSIONS AND LESSONS LEARNED

This research program has enabled to develop a complete demonstrator integrating an original actuation system based on SMA actuators. At the end of the demonstration phase, most of the requirements have been fulfilled. Therefore, the real application of such a concept on an existing Air Vehicle, like an HALE-UAV appears realistic.

The main advantages of this actuation system are the following :

- Size and mass of the system
- electrical supply under low voltage (All Electrical Aircraft)
- elastic hinge simplicity
- self locking concept (toggle joint+elastic hinge)
- power needed only for actuation and compatible with available energy on a Hale (1000 W input in several times)

However, some limitations remain :

- SMA behaviour complexity, especially under cyclic conditions (elongation...)
- number of mechanical parts

Especially for the first item, further development would be needed :

- completion of the characterization at very low temperature
- aeroelastic behaviour of the TE shall be checked (analysis, testing)
- better understanding of the SMA wires behaviour, especially under cyclic life - set-up of simulation models
- Improvement of SMA procurement : interaction with the suppliers, definition of specifications and receipt criteria

ACKNOWLEDGMENTS

The author wish to thank the French MOD DGA for their financial support, especially in the frame of the CASS project.

SYMPOSIA DISCUSSION – PAPER NO: 13**Author's Name: B. Berton****Question (V. Agarwala):**

NiTi SMA undergoes certain amount of hysteresis, which means certain loss of reversibility. The question was how many cycles can you go through using SMA wires before you will have to replace them; And then, how does that complicate maintenance and affordability?

Author's Response:

Indeed, the NiTi wires used show some hysteresis. After more than one thousand cycles, the hysteresis has changed a little but we have still the needed recovery strain (about 2.5 %); Therefore, with our selected concept, we don't envisage to replace the actuators during the life of the UAV (~ 2000 cycles). Anyway, if needed, the replacement could be done rather easily (at mid life) since the SMA actuators are located in an aileron box that is accessible.

Question (E. Wetzel):

The existing system uses SMAs with A_s temperature around 70°C. At low ambient temperatures (-55°C), more electrical power is required to enable actuation. Would it be possible to use a combination of both low A_s and high A_s SMA wires to improve performance over full temperature range?

Author's Response:

It would be needed to use different wires with different temperature transitions; therefore the complexity of the system would increase largely. Moreover, the temperature/stress relationship behaviour should be taken into account (complex design).

Shape Memory Alloys Application: Trailing Edge Shape Control

